

蓋

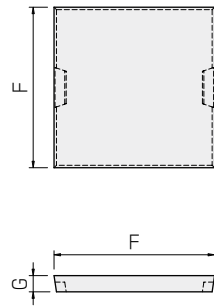

本体

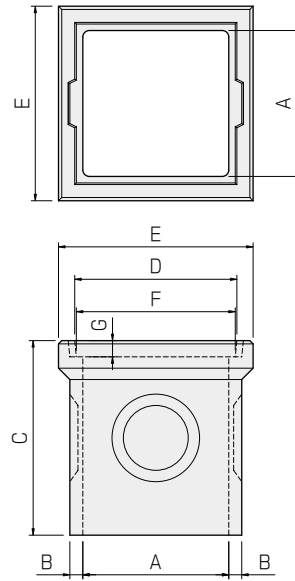

呼び		寸法(mm)							参考重量 (kg)
		A	B	C	D	E	F	G	
240	本体	240	30	380	270	340	260	33	28
	蓋	—	—	—	—	—	260	33	5
300	本体	300	30	450	330	410	320	33	42
	蓋	—	—	—	—	—	320	33	8
360	本体	360	35	500	400	490	390	46	76
	蓋	—	—	—	—	—	395	46	17
450	本体	450	40	600	500	600	490	50	115
	蓋	—	—	—	—	—	495	50	27
600	本体	600	50	650	650	750	640	—	198
	蓋	—	—	—	—	—	645	50	46

## 改良桝

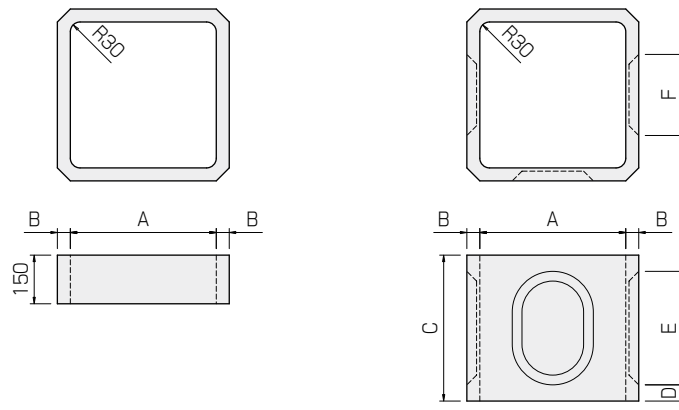

呼び		寸法(mm)						参考重量 (kg)
		A	B	C	D	E	F	
300	H150	300	33	150	—	—	—	15
	H300	300	33	300	75	150	150	28
360	H150	360	36	150	—	—	—	19
	H300	360	36	300	50	200	200	38
450	H150	450	40	150	—	—	—	27
	H300	450	40	300	—	—	—	50
	H450	450	40	450	50	350	250	75
600	H150	600	50	150	—	—	—	45
	H300	600	50	300	—	—	—	90
	H600	600	50	600	50	410	310	180