

C型蓋

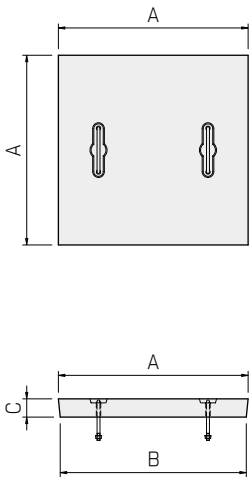

縁塊

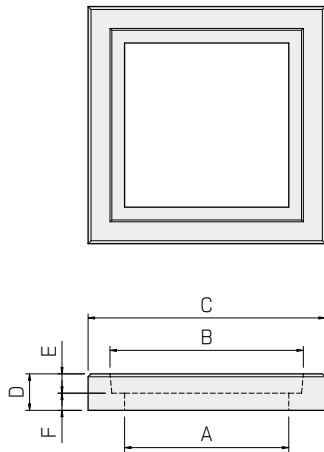

側塊

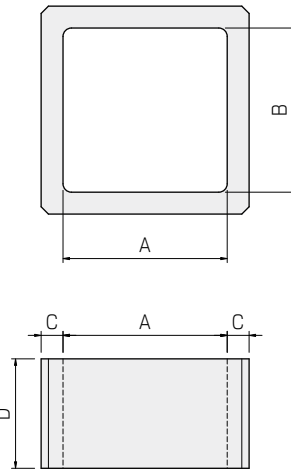

※側塊

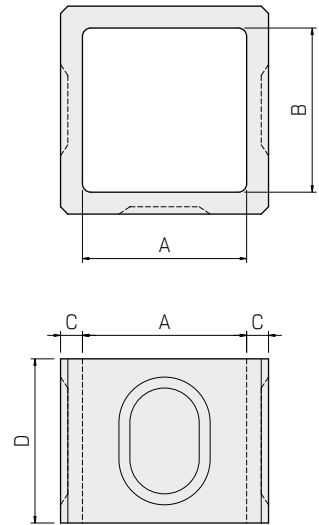

呼び	寸法(mm)						参考重量(kg)	
	A	B	C	D	E	F		
蓋	300	370	360	50	—	—	17	
	360	430	420	50	—	—	23	
	450	520	510	50	—	—	33	
	500	570	560	50	—	—	38	
	600	670	660	60	—	—	63	
縁塊	300	300	380	500	100	53	47	32
	360	360	440	560	100	53	47	36
	450	450	530	650	100	53	47	42
	500	500	580	700	100	53	47	47
	600	600	680	800	100	63	37	55
側塊 300	H150	300	300	50	150	—	—	25
	H300	300	300	50	300	—	—	50
側塊 360	H100	360	360	50	100	—	—	20
	H150	360	360	50	150	—	—	30
	H300	360	360	50	300	—	—	58
	※H360	360	360	50	360	—	—	68
側塊 450	H100	570	450	60	100	—	—	28
	H150	570	450	60	150	—	—	43
	H300	570	450	60	300	—	—	85
	※H450	570	450	60	450	—	—	128
側塊 500	H150	620	500	60	150	—	—	48
	H300	620	500	60	300	—	—	94
側塊 600	H100	720	600	60	100	—	—	40
	H150	720	600	60	150	—	—	56
	H300	720	600	60	300	—	—	120
	※H600	720	600	60	600	—	—	230
底版塊	300	470	290	60	—	—	—	30
	360	520	350	60	—	—	—	37
	450	630	440	60	—	—	—	55
	600	780	590	60	—	—	—	84
鑄物入り 縁塊	300	500	300	100	100	—	—	43
	350	560	350	100	105	—	—	52
	450	650	450	100	100	—	—	61
	500	700	500	100	100	—	—	72
	600	800	600	100	100	—	—	83

底版塊

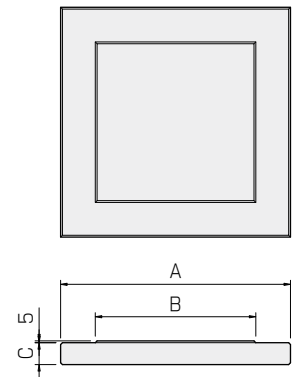

鑄物入り縁塊

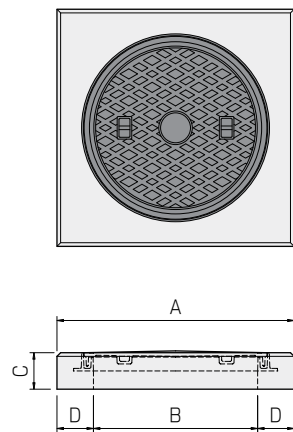

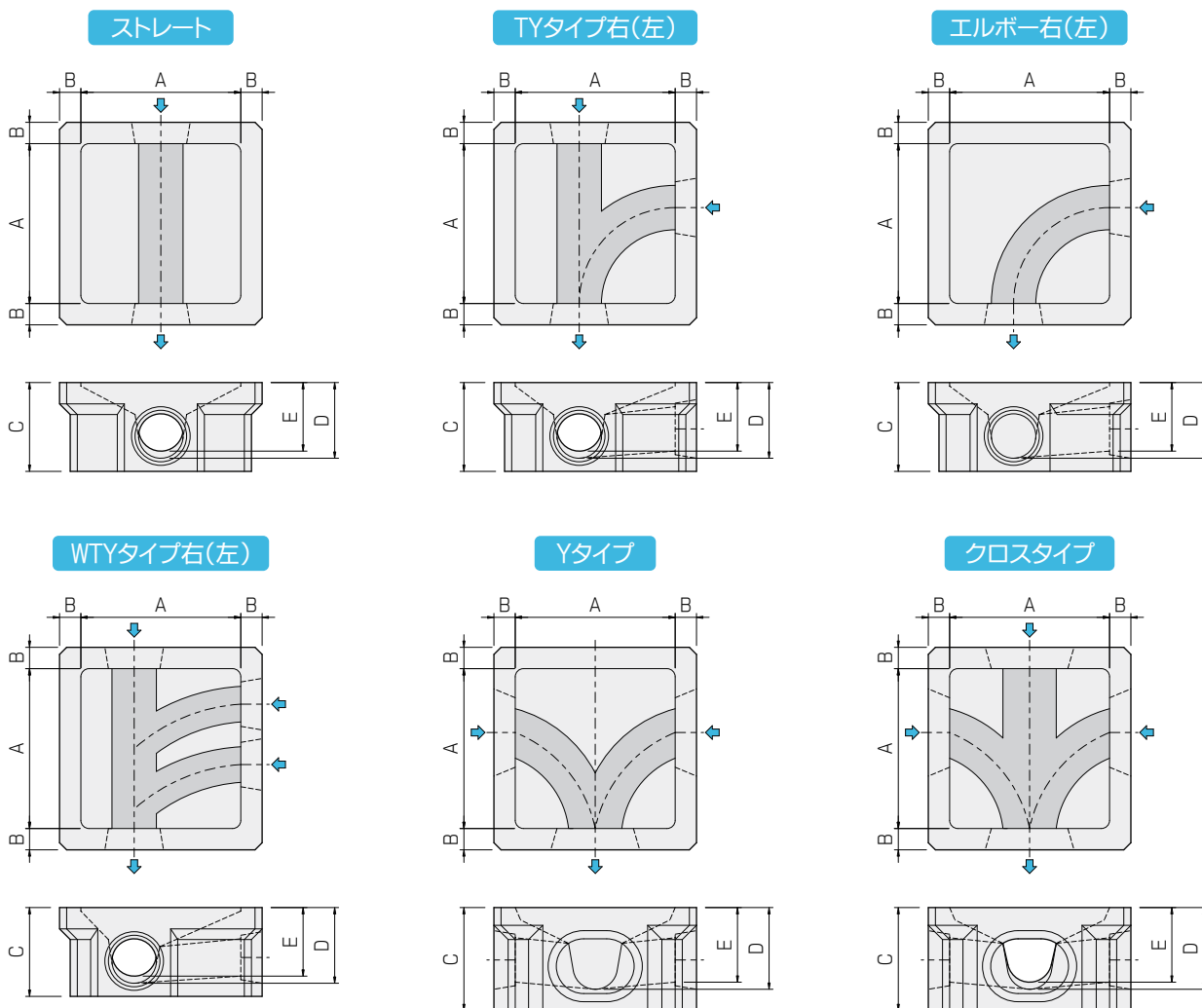

呼び	インバート種類	接続配管径 (VP,VU管)	寸法(mm)					参考重量 (kg)
			A	B	C	D (OUT)	E (IN)	
360	ストレート	100	360	50	250	215	205	67
	TYタイプ(右、左)	100	360	50	250	215	205	60
	エルボー(右、左)	100	360	50	250	215	205	67
450	ストレート	100	450	60	250	204	184	110
		125	450	60	250	213	193	110
		150	450	60	250	240	220	109
	TYタイプ(右、左)	100	450	60	250	204	184	109
		125	450	60	250	213	193	109
		150	450	60	250	240	220	109
	エルボー(右、左)	100	450	60	250	204	184	109
		125	450	60	250	213	193	109
		150	450	60	250	240	220	109
	WTYタイプ(右、左)	100×100	450	60	250	205	195	86
125×100		450	60	250	210	190	86	
150×100		450	60	250	250	230	86	
Yタイプ	125×150	450	60	290	230	210	100	
クロスタイプ	125×150	450	60	290	230	210	100	
600	ストレート	100	600	60	250	204	184	193
		125	600	60	280	243	223	193
		150	600	60	283	243	223	193
	TYタイプ(右、左)	100	600	60	250	204	184	185
		125	600	60	280	243	223	185
		150	600	60	283	243	223	185
	エルボー(右、左)	100	600	60	250	204	184	193
		125	600	60	280	243	223	193
		150	600	60	283	243	223	193
	WTYタイプ(右、左)	125×100	600	60	250	210	190	135
		150×100	600	60	310	250	230	135
	Yタイプ	150	600	60	311	250	230	166
	クロスタイプ	150	600	60	311	250	230	200